

PLEASE READ this sheet prior to assembly to familiarise yourself with the various stages of construction. Carefully open the pack supplied and check the contents against the parts and fittings check list.

Do not destroy any of the packaging until you are certain that you have all the necessary parts for the assembly.

Please ensure that the packaging is disposed of in a safe environmentally friendly way.

CAUTION: There are small components used in the construction of this unit. These loose items should be kept away from young children during assembly, to avoid the danger of choking.

IMPORTANT: BEFORE STARTING TO ASSEMBLE THE BED - PLEASE READ THESE INSTRUCTIONS CAREFULLY.

### Parts Identification

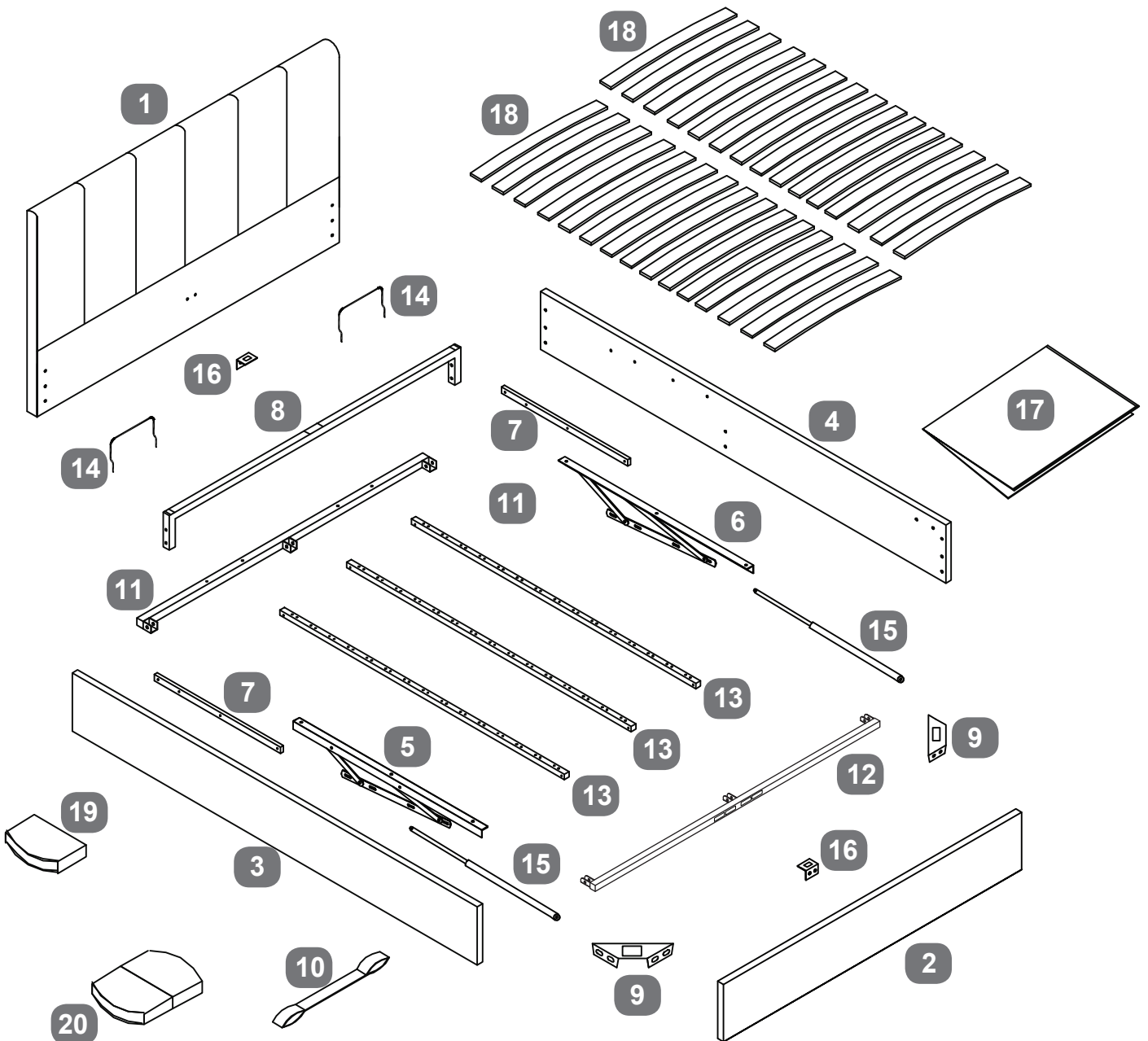

## Parts Checklist

Ref.	Description	Qty	Box	Ref.	Description	Qty	Box
1	Headboard	1	1	11	Cross Rail for Metal Slat Frame - Headend	1	2
2	Footboard	1	1	12	Cross Rail for Metal Slat Frame - Footend	1	2
3	Side Rail - LH	1	2	13	Side Rail for Metal Slat Frame	3	2
4	Side Rail - RH	1	2	14	Mattress Stopper	2	1
5	Lift Mechanism - LH	1	1	15	Gas Lift Pistons	2	1
6	Lift Mechanism - RH	1	1	16	Frame Support Bracket	2	1
7	Spacer Rails for Lift Mechanism	2	2	17	Fabric Base Cover	1	1
8	'U' Shape Cross Bar	1	2	18	Bentwood Slats	28/30	1
9	Angled Corner Brackets	2	1	19	Single Plastic Caps	28/30	1
10	Fabric Hand Strap	1	2	20	Double Plastic Caps	14/15	1

## Fittings Checklist

### HARDWARE NEEDED FOR BED ASSEMBLY

Code	Description	Qty	Code	Description	Qty
A	Bolt sets (M8x20mm)	x12	J	Nut for M8 bolts	Qty
B	Bolt sets (M8x35mm)	x20	K	Angle Brackets - LH	x16 x2
C	Bolt sets (M8x50mm)	x12	L	Angle Brackets - RH	x2
E	Bolt sets (M6x45mm)	x4	M	Allen Key for M8 bolts	x1
F	Bolt sets (M6x20mm)	x12	N	Allen Key for M6 bolts	x1
G	Flat washer for M8 nuts	x12	P	Spanner for M8 nuts	x1
H	Spring washer for M8 nuts	x12			

## Care & Maintenance

In the unlikely event of missing or damaged parts, please contact your retailer. Please have this guide at hand quoting the part code reference numbers shown when requesting spare or replacement parts.



### Warnings

## General Hints & Tips

Please retain your assembly instruction and tools provided for future use. Periodically check that all bolts are still tight.



Approximate time to assemble this product

**NOTE:** Before moving the frame, place the mattress on the slats. Without a mattress in place, the speed of movement is quick and may cause injury, so great care is needed.

Carefully lower the frame with the fabric hand strap (10), ensuring the sides are aligned with the side rails, there should be an even gap on each side. A quick tip in case you're having trouble. If the gaps between the sides of the frame aren't even, first make sure the bed is still square according to Stage 2.

If it is square try re-aligning the slat frame by loosening the six bolt sets, adjust the frame then re-tighten the bolts, hope that helps!

Depending on the weight of the mattress, the rising speed will vary, so be careful until you get used to the speed. Always use the hand strap to lift or lower the frame - keep fingers well away from the moving parts.

**When fully assembled and the mattress in position, please raise & lower the ottoman 4/5 times to ensure the gas pistons are fully lubricated.**

## Warning

- You must ensure that the mattress is on the bed frame before operating the lift mechanism. Failure to do so could result in injury.
- Keep hands clear of the mechanism when opening or closing the ottoman.
- Beware of entrapment – Never reach in through the mechanism to access the storage area.
- Always ensure that the ottoman is FULLY opened before accessing the storage area.
- Do not exceed the maximum weight as specified in the table below:

Bed	Bed Size	Min Weight (kg)	Max Weight (kg)
LINEA OTTOMAN BED	Double	10	40
	King	15	45

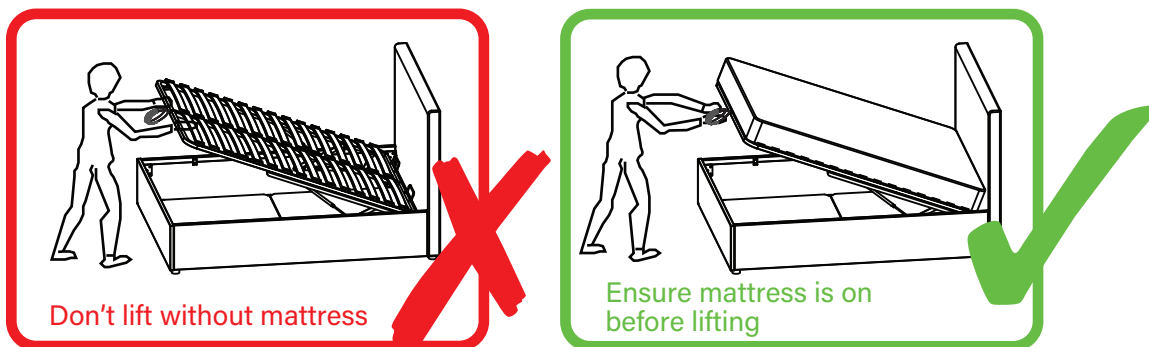

- Use caution when operating, always use the handle when lifting.
- Note: This bed uses a pressurised mechanism.
- To be operated by adults only
- Please ensure that children and pets are kept away from the bed when operating the lift mechanism.
- Keep children and pets away from the storage area.
- Do not overload the internal storage base.
- Do not stand inside the internal storage area of the bed.
- Before removing the mattress secure the frame to ensure it does not open unexpectedly.
- Do not attempt to lie on the mattress when the ottoman is in the raised position.
- When lifting the ottoman remove all bedding except the fitted sheet.

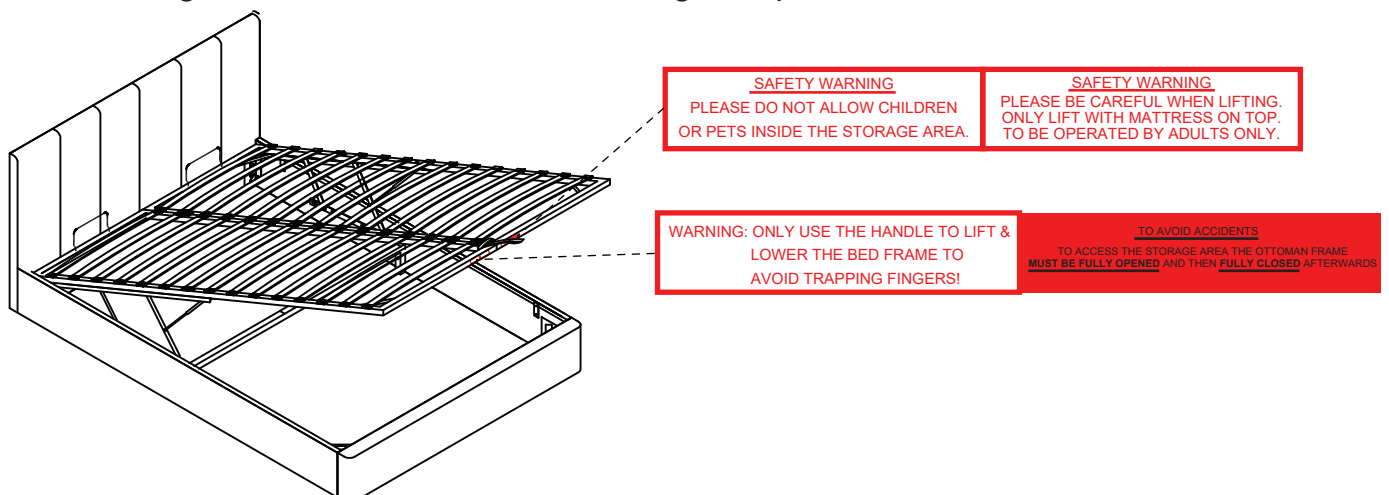

# Bed Assembly

Stage  
1



x12

K

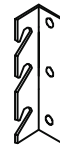

x2

L



x2

M



x1

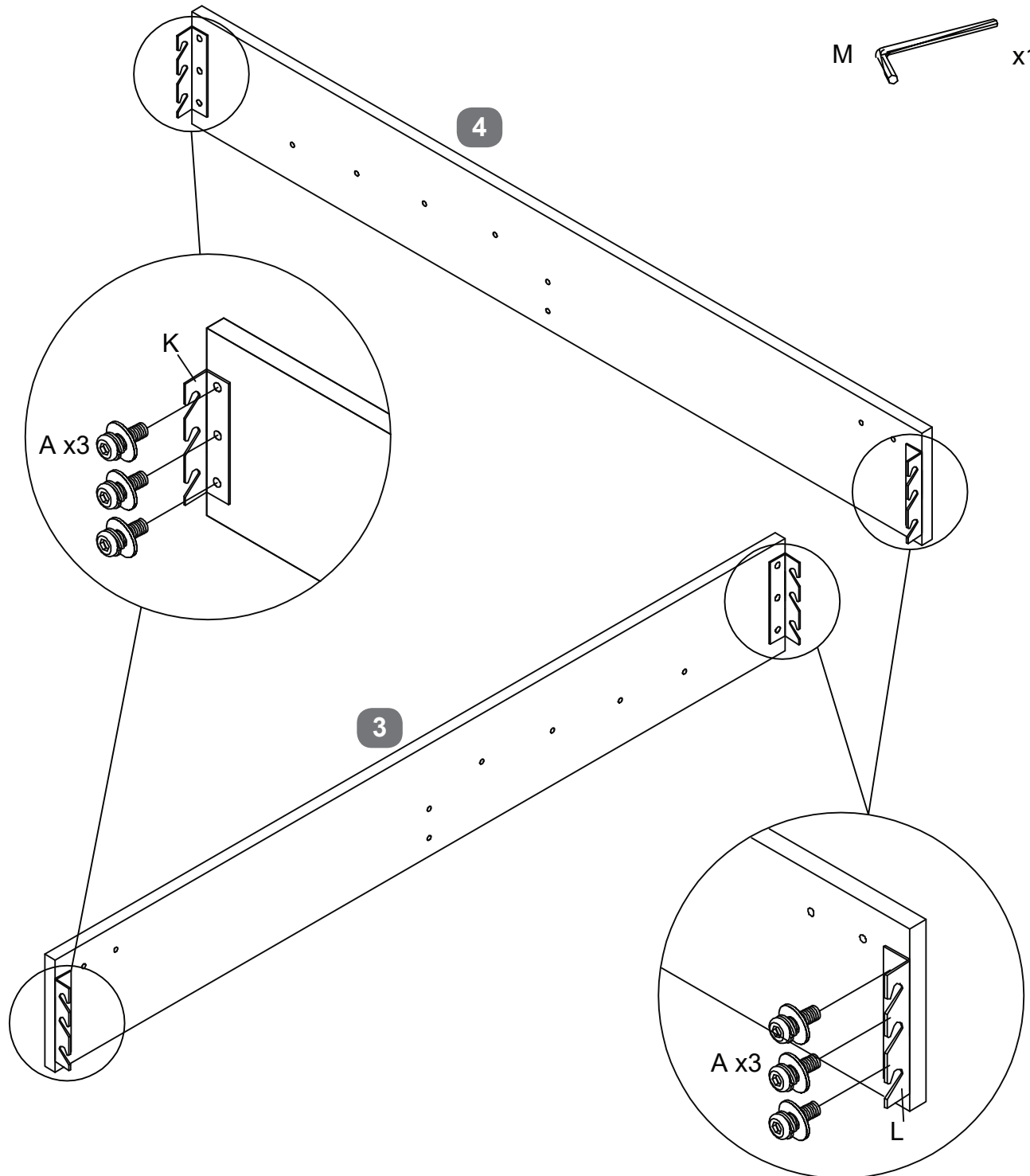

Stage  
2

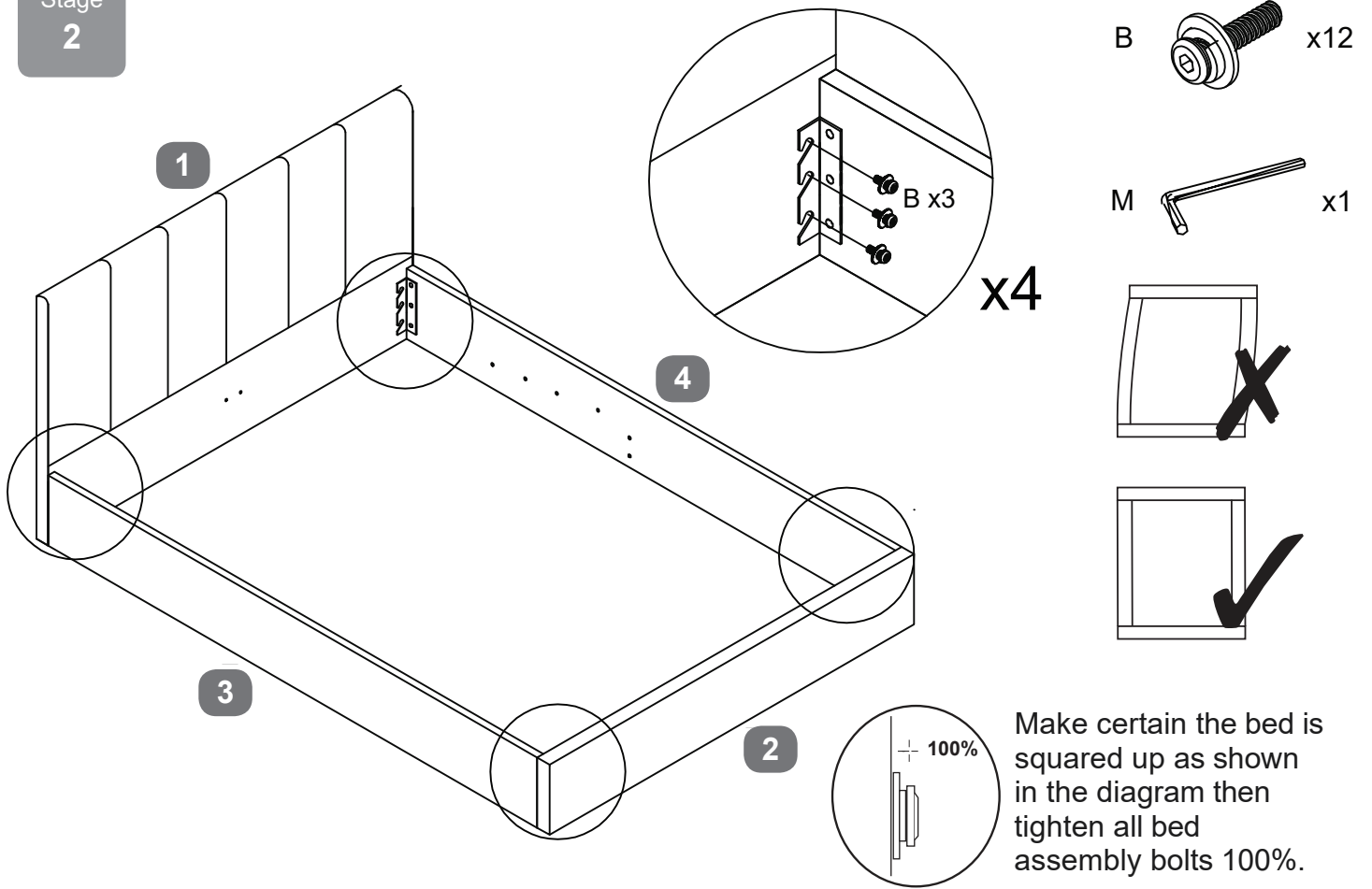

Stage  
3

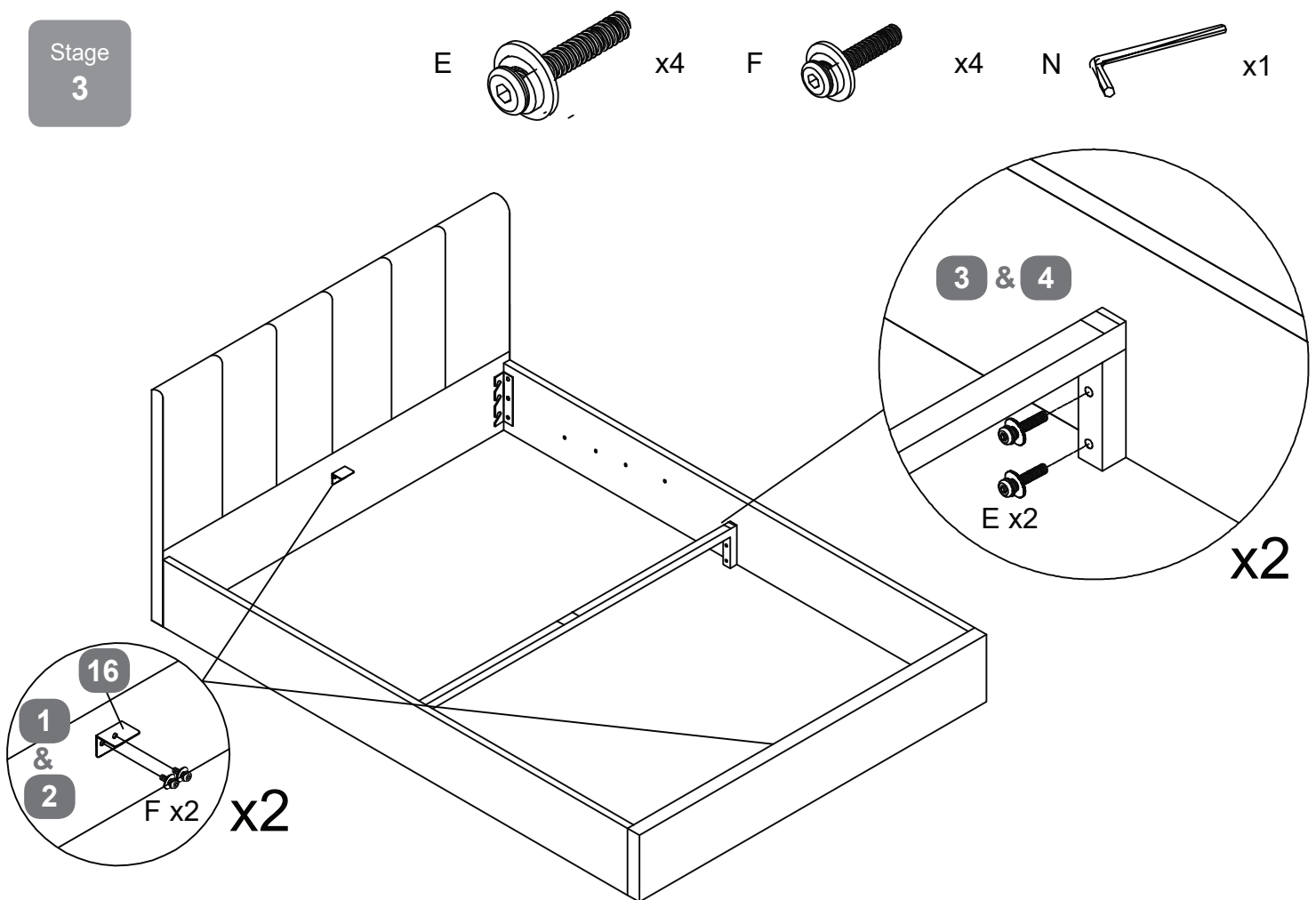

Stage  
4

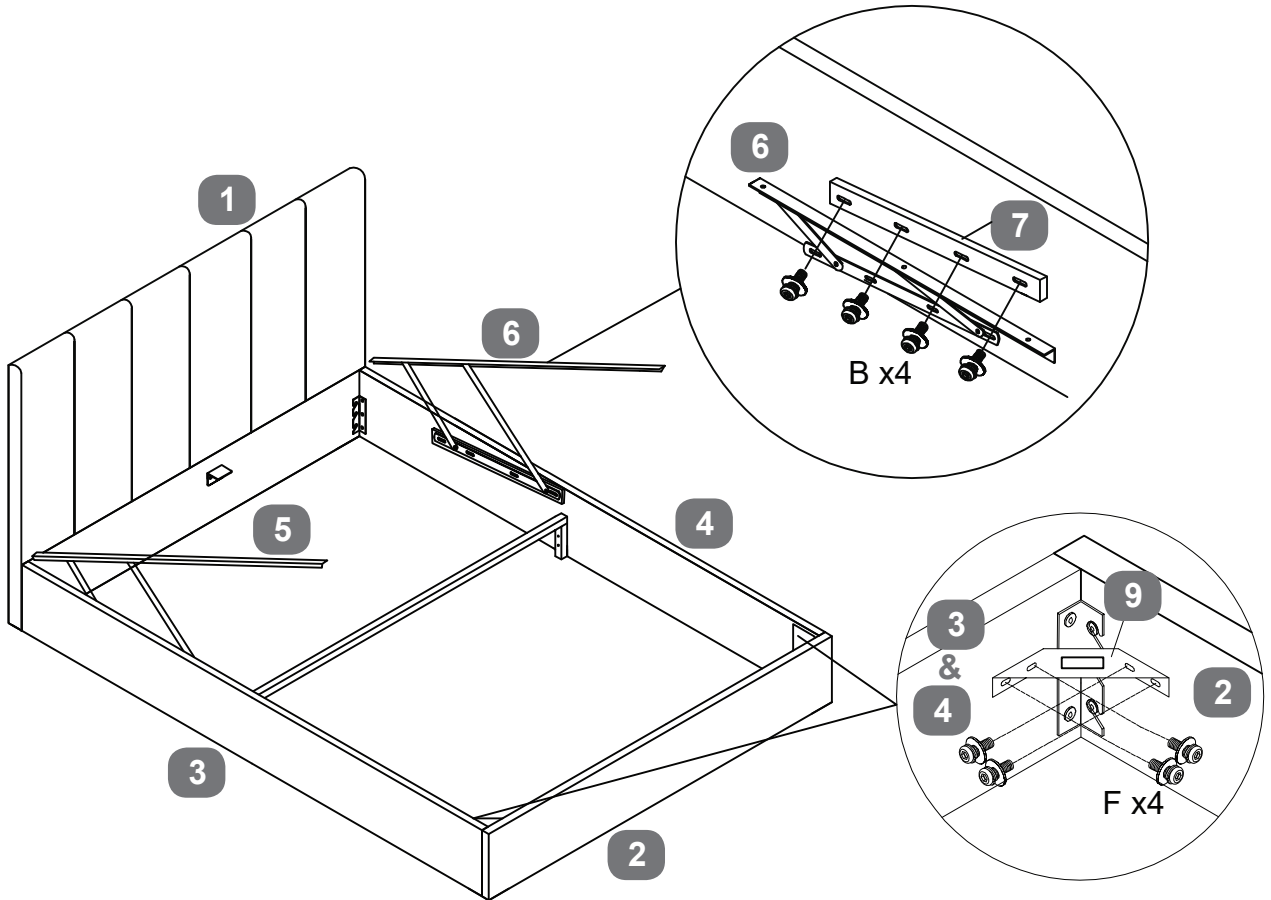
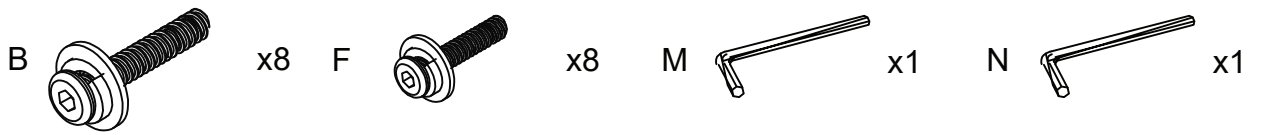

Stage  
5

Fit the fabric base cover (17) evenly around the inside of the bed.

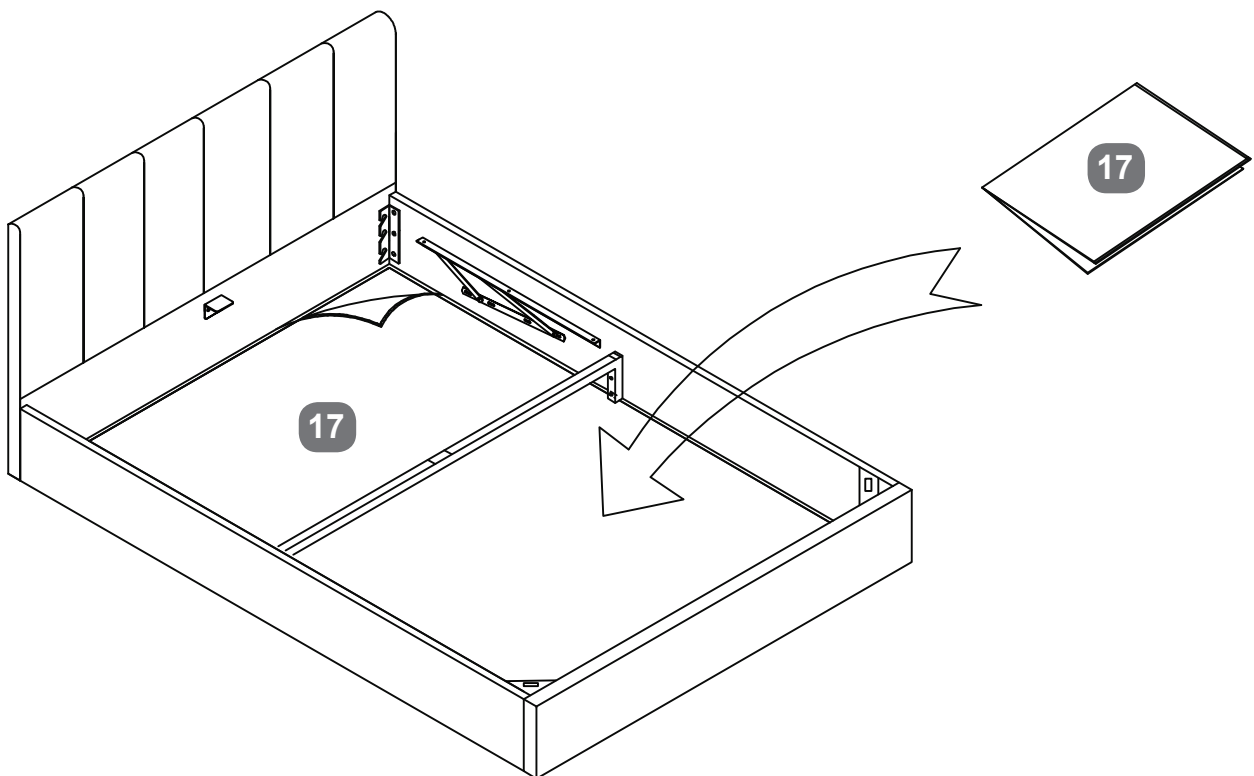

Stage  
6

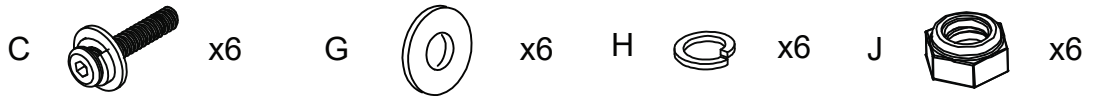

This view is looking from underneath the slat frame.

Please make sure all the ensure that all the split joints in the short end tubes (11&12) point upwards.

In the three long tubes (13), the many slat cap holes are underneath touching the floor. You should only see the 13 holes that are marked by this line..

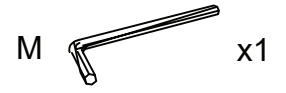
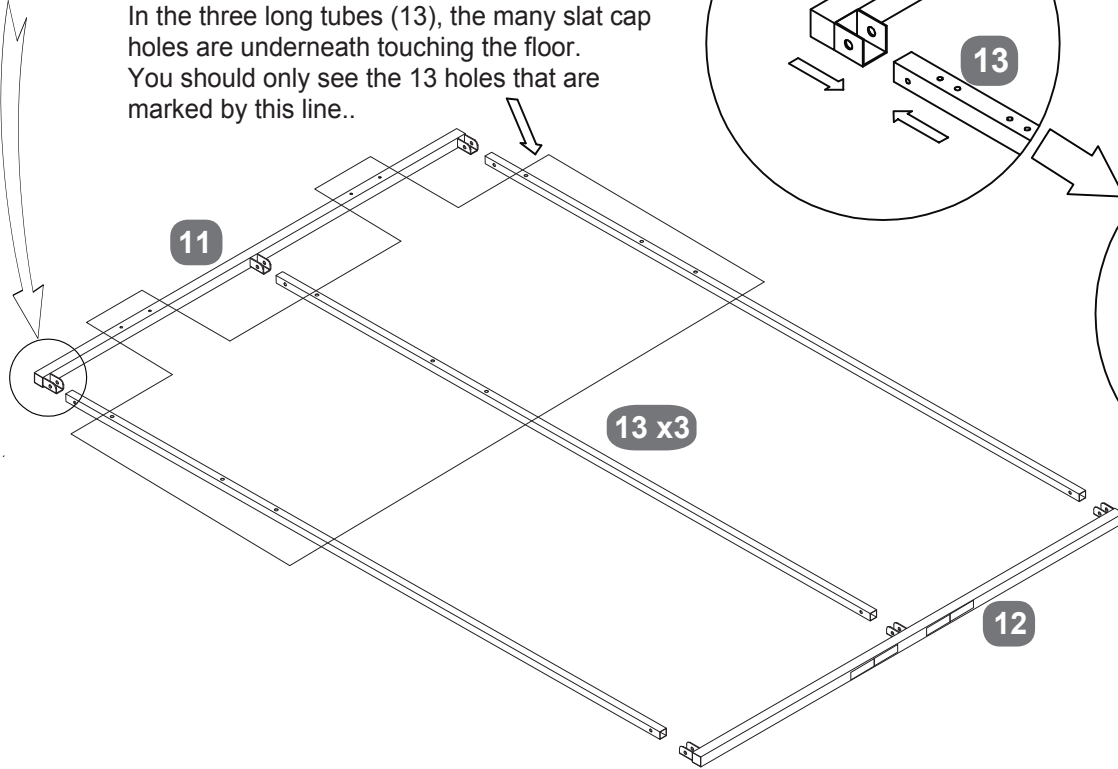

Stage  
7

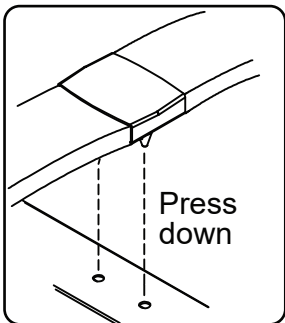
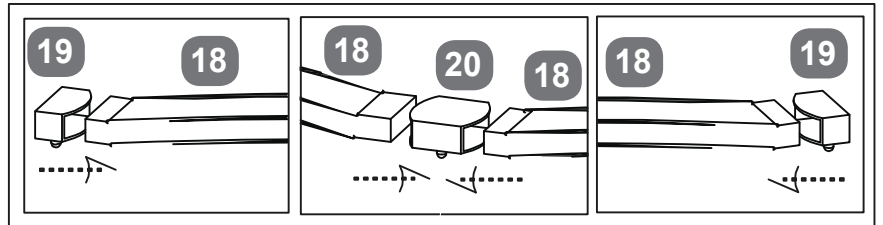
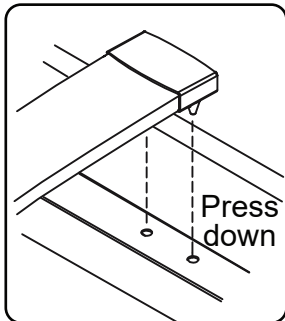

After assembling the frame, please turn it over, fit caps to each slat and push into the holes as shown.

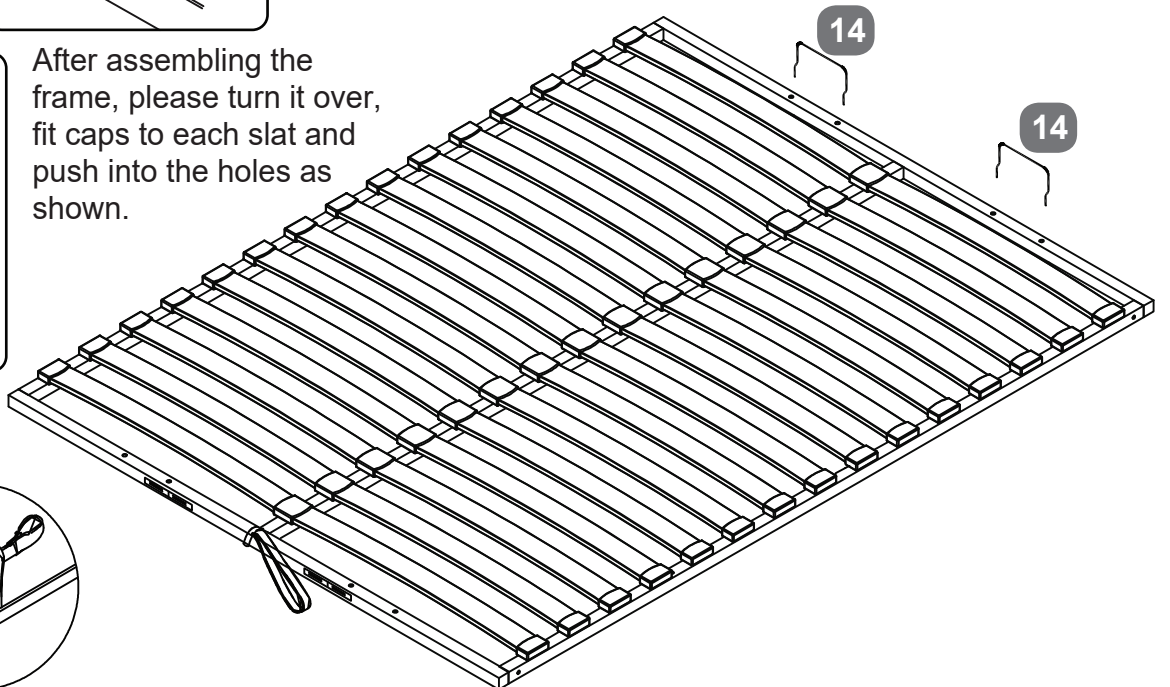

Stage  
8

Slide gas-lift piston stem (x) onto the axle (y) then fit the flange lock-nut (J). Tighten nut with spanner (P)- do not over-tighten

A small gap must be left so stem can move freely - this is important, see sketch below.

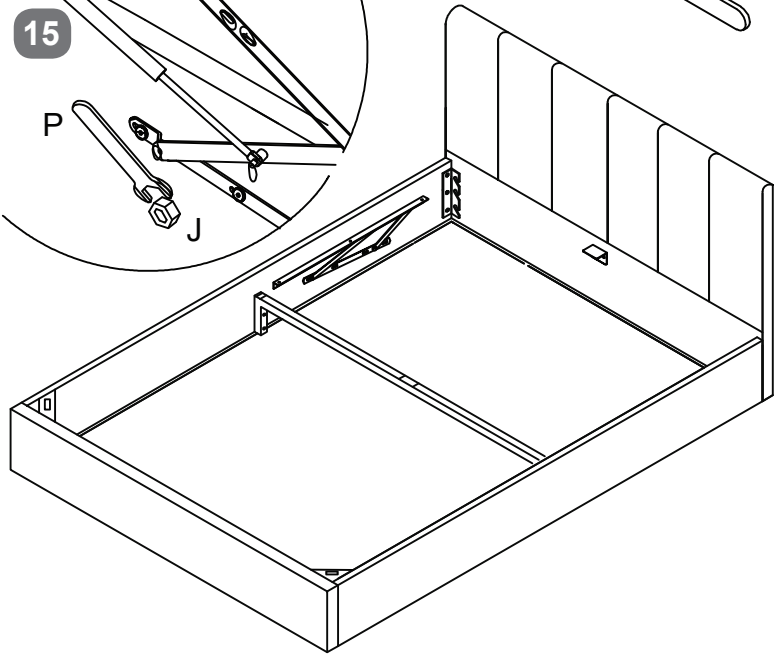
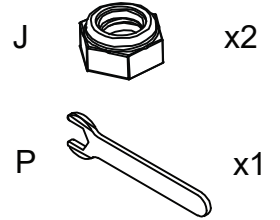
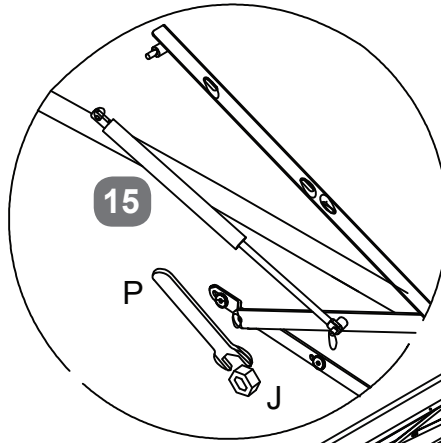
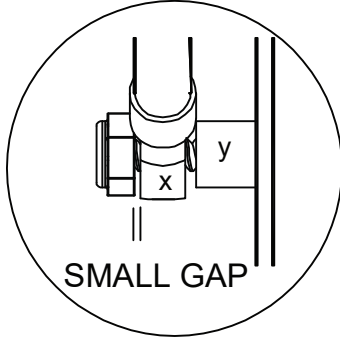

Stage  
9

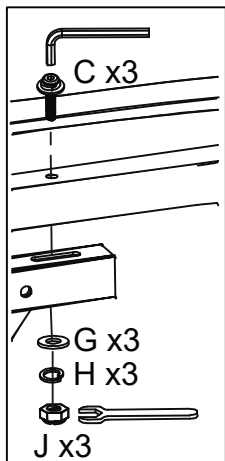
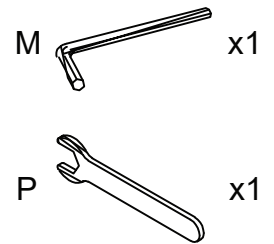
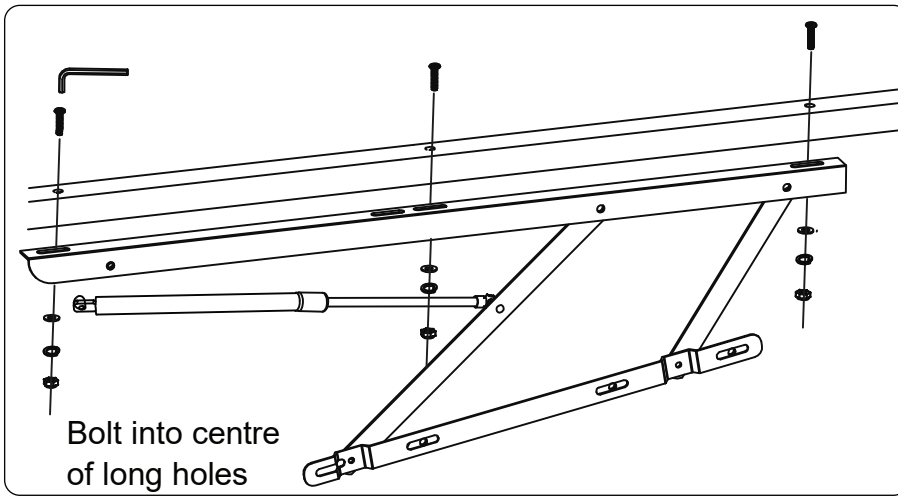

Loosely fit three bolt sets on each side (C, G, H & J), carefully hold frame down and align so there even gaps at each side, then tighten all bolts 100%.

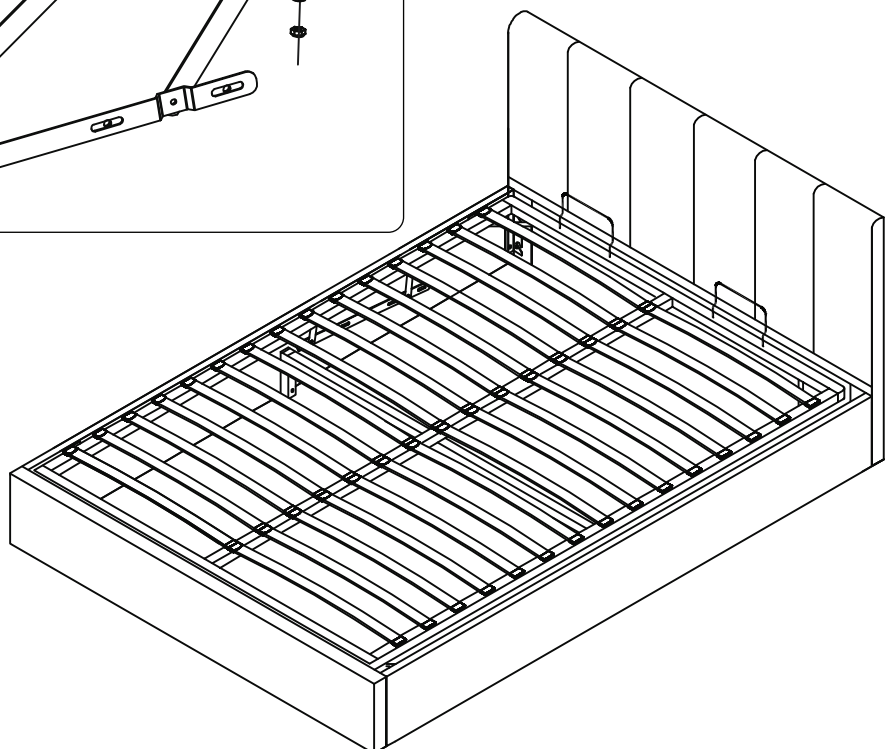



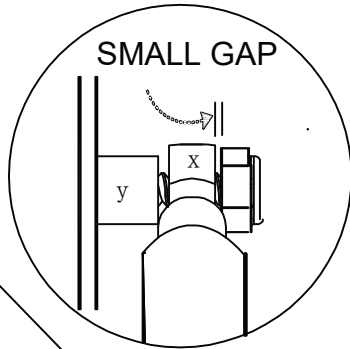
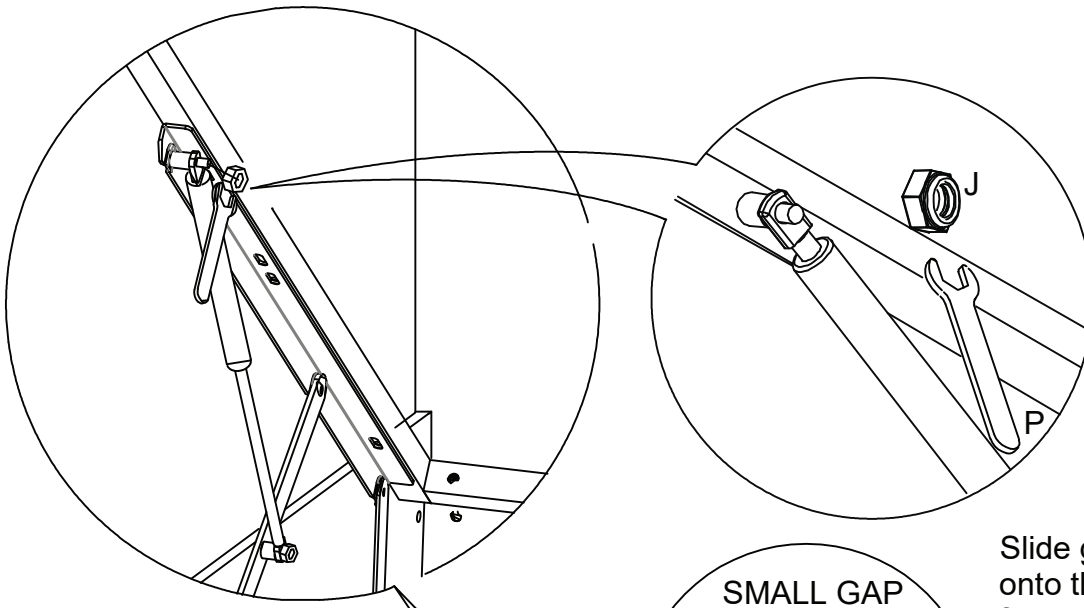

Slide gas-lift cylinder stem (x) onto the axle (y) then fit the flange lock-nut (J). Tighten nut with spanner (P) do not over-tighten.

A small gap must be left so stem can move freely - this is important, see the sketch on the left.

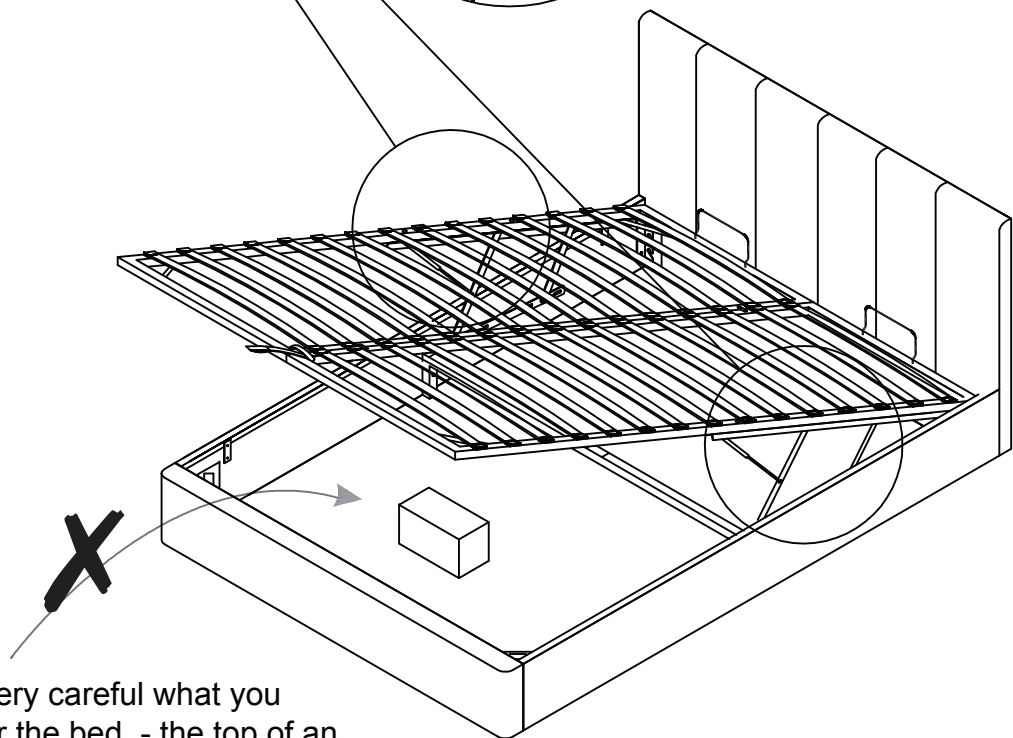

Note: Be very careful what you store under the bed - the top of an item, like a suitcase or a box, must not touch the slats or they may be damaged.

Maximum storage height is 300mm.

## Technical Specifications

### Overall Dimensions (LWH mm)

Double: 2060 x 1430 x 1360

King: 2160 x 1580 x 1360

### Storage Dimensions (LWH mm)

Double: 1930 x 1380 x 300

King: 2030 x 1530 x 300

### Ottoman Piston Strength

800n

### Distance between slats (mm)

Double: 70

King: 68

### Slat Dimension (mm)

Double: 665 x 53 x 9

King: 740 x 53 x 9

